



TechSpray Sprl
Rue Ernest Matagne 32 - Module 1
5330 Assesse - BELGIUM
Phone: +32 (0) 83 65 56 08 - Fax: +32 (0) 83 67 85 05
info@techspray.be - www.techspray.be

Accessoires

NOZZLES

IT EN E





ACCESSORI

ACCESSORIES

ACCESORIOS

GHIERE + CORPO PORTAUGELLO RETAINERS + NOZZLE HOLDERS VIROLAS + CUERPO PORTABOQUILLAS	p. 74	RACCORDI A FASCETTA MOD. E MOD. E SPLIT EYELET CONNECTORS UNIONES DE ABRAZADERA MOD. E	p. 77
FILTRI PER UGELLI FILTERS FOR NOZZLES FILTROS PARA BOQUILLAS	p. 74	RACCORDI A FASCETTA MOD. DA MOD. DA SPLIT EYELET CONNECTORS UNIONES DE ABRAZADERA MOD. DA	p. 77
GHIERA ATTACCO RAPIDO QUICK FIT RETAINER VIROLA PARA CONEXIÓN RÁPIDA	p. 74	RACCORDI A FASCETTA MOD. BA MOD. BA SPLIT EYELET CONNECTORS UNIONES DE ABRAZADERA MOD. BA	p. 77
SNODI PORTAUGELLO PP PP SWIVEL NOZZLE HOLDERS ARTICULACIONES PARA PORTABOQUILLAS PP	p. 75	RACCORDI FASCETTA ZINCATA PLATED SPLIT EYELET CONNECTORS UNIONES DE ABRAZADERA GALVANIZADA	p. 78
SNODI PORTAUGELLO OTTONE BRASS NOZZLE HOLDER SWIVELS ARTICULACIONES PARA PORTABOQUILLAS DE LATÓN	p. 75	SNODO ORIENTABILE OTTONE/INOX ADJUSTABLES SWIVELS IN BRASS/SS303 ARTICULACIÓN ORIENTABLE LATÓN/INOX	p. 79
RACCORDI A FASCETTA MOD. C MOD. C SPLIT EYELET CONNECTORS UNIONES DE ABRAZADERA MOD. C	p. 76	SNODO ALTA PRESSIONE HIGH PRESSURE SWIVELS ARTICULACIÓN ORIENTABLE ALTA PRESIÓN	p. 80
RACCORDI A FASCETTA MOD. D MOD. D SPLIT EYELET CONNECTORS UNIONES DE ABRAZADERA MOD. D	p. 76	PORTAUGELLO A SFERA ATTACCO RAPIDO SPHERE NOZZLE HOLDER QUICK THREAD PORTABOQUILLAS DE ESFERA CONEXIÓN RÁPIDA	p. 81
RACCORDI A FASCETTA MOD. A MOD. A SPLIT EYELET CONNECTORS UNIONES DE ABRAZADERA MOD. A	p. 76	SERBATOIO PRESSURIZZATO PRESSURE TANK DEPÓSITO PRESURIZADO	p. 83
RACCORDI A FASCETTA MOD. B MOD. B SPLIT EYELET CONNECTORS UNIONES DE ABRAZADERA MOD. B	p. 76		

GHIERE + CORPO PORTAUGELLO

RETAINERS + NOZZLE HOLDERS

VIOLAS + CUERPO PORTABOQUILLAS



Caratteristiche

Ghiera 3/8" per tutte le testine di spruzzo del catalogo.

Disponibile in ottone, acciaio AISI 303 e AISI 316. Corpo portaugello in ottone o acciaio AISI 303 e AISI 316.

Attacchi: 1/8"-1/4"-3/8" M o F.

Characteristics

Retainer 3/8" for all type of tips on catalogue.

Available in brass, stainless steel 303 and stainless 316. Body nozzle holder in brass or stainless steel 303 and stainless 316.

Thread: 1/8"-1/4"-3/8" M or F.

Características

Virola 3/8" para todos los cabezales rociadores del catálogo.

Se presenta en latón, acero AISI 303 e AISI 316. Cuerpo de portaboquillas en latón o acero AISI 303 y AISI 316.

Conexiones: 1/8"- 1/4"- 3/8" M o H.

FILTRI PER UGELLI

FILTERS FOR NOZZLES

FILTROS PARA BOQUILLAS

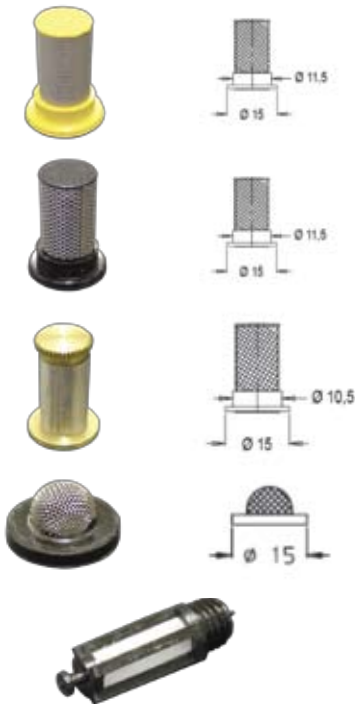

Filtro - Filter - Filtro

Codice - Code - Código	Filtrazione mesh - Filtration mesh - Filtrado mesh
PFILTRO 5 PFILTRO A	50 100

Filtro con antigoccia - Check valve filter - Filtro con antigoteo

Codice - Code - Código	Filtrazione mesh - Filtration mesh - Filtrado mesh
PFILTRO 5A PFILTRO AA	50 100

Filtro - Filter - Filtro

Codice - Code - Código	Filtrazione mesh - Filtration mesh - Filtrado mesh
OFILTRO 5A OFILTRO AA	50 100

Filtro a cupola - Cup filter - Filtro de cúpula

Codice - Code - Código	Filtrazione mesh - Filtration mesh - Filtrado mesh
PFILTRO CUP	50

Filtro per modello MC2 - MC2 filter - Filtro para modelo MC2

Codice - Code - Código	Grado filtrazione - Filtration degree - Grado de filtración	Attacco - Thread - Rosca de conexión
PFILTROM 100M	100MESH	M7

GHIERA ATTACCO RAPIDO

QUICK FIT RETAINER

VIROLA PARA CONEXIÓN RÁPIDA



Per modelli For model Para modelos

C1 - KC1 getto a lama
flat jet
chorro en lámina

Per modelli For model Para modelos

C1 - KC1 getto a lama e spillo
flat and needle jet
chorro en lámina y aguja

CODICE GHIERA RETAINER CODE CÓDIGO VIROLA	CODICE GUARNIZIONE GASKET CODE CÓDIGO GUARNICIÓN	CODICE GHIERA RETAINER CODE CÓDIGO VIROLA	CODICE GUARNIZIONE GASKET CODE CÓDIGO GUARNICIÓN
PGHIERA A03 rossa red roja PGHIERA A04 blu blue azul PGHIERA A01 nera black negra PGHIERA B03 rossa red roja PGHIERA D03 rossa red roja PGHIERA E03 rossa red roja PGHIERA F03 rossa red roja PGHIERA G03 rossa red roja	PGUARNIZIONE AV PGUARNIZIONE AV PGUARNIZIONE AV PGUARNIZIONE AV PGUARNIZIONE AV PGUARNIZIONE AV PGUARNIZIONE AV PGUARNIZIONE AV PGUARNIZIONE AV	PGHIERA G04 blu blue azul PGHIERA H03 rossa red roja PGHIERA I03 rossa red roja PGHIERA L01 rossa red roja PGHIERA M03 nera black negra PGHIERA N03 rossa red roja 200010R	PGUARNIZIONE AV PGUARNIZIONE AV PGUARNIZIONE AV PGUARNIZIONE AV PGUARNIZIONE AV PGUARNIZIONE AV PGUARNIZIONE AV PGHIERA

SNODI PORTAUGELLO PP

PP SWIVEL NOZZLE HOLDERS

ARTICULACIONES PARA PORTABOQUILLAS PP



Portaugelli snodato - Articulated nozzle holder - Portaboquillas articulado

Codice - Code - Código	Attacco - Thread - Rosca de conexión
PSNOD1SG PSNOD2SG	G 1/4" (BPS) G 3/8" (BPS)

Portaugelli snodato doppio - Double articulated nozzle holder - Portaboquillas articulado doble

Codice - Code - Código	Attacco - Thread - Rosca de conexión
PSNOD1F2MG PSNOD2F2MG	G 1/4" (BPS) G 3/8" (BPS)

SNODI PORTAUGELLO OTTONE

BRASS NOZZLE HOLDER SWIVELS

ARTICULACIONES PARA PORTABOQUILLAS DE LATÓN

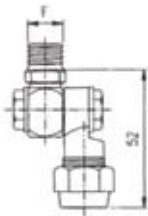
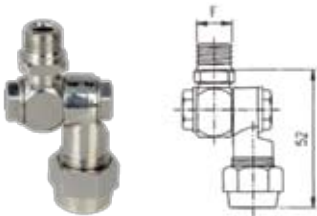

Portaugelli snodati con ghiera 3/8" - Nozzle holder swivels with retainer 3/8" - Portaboquillas articulados con virolas 3/8"

Lunghezza - Length - Longitud	Codice - Code - Código	Attacco - Thread - Rosca de conexión
52	OSNODOS1M2M	G 1/4" M

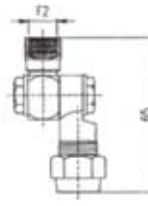

Lunghezza - Length - Longitud	Codice - Code - Código	Attacco - Thread - Rosca de conexión
65	OSNODOS1F2M	G 1/4" F

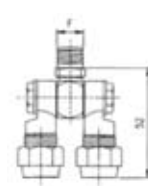

Portaugelli snodati doppio con ghiera 3/8" - Double nozzle holder swivels with retainer 3/8" - Portaboquillas articulados dobles con virolas 3/8"

Lunghezza - Length - Longitud	Codice - Code - Código	Attacco - Thread - Rosca de conexión
52	OSNODOD1M2M	G 1/4" M

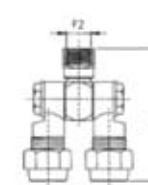
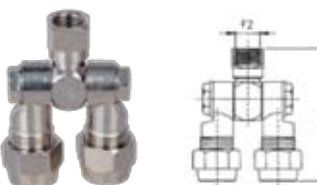

Lunghezza - Length - Longitud	Codice - Code - Código	Attacco - Thread - Rosca de conexión
65	OSNODOD1F2M	G 1/4" F



RACCORDI A FASCETTA MOD. C

MOD. C SPLIT EYELET CONNECTORS
UNIONES DE ABRAZADERA MOD. C

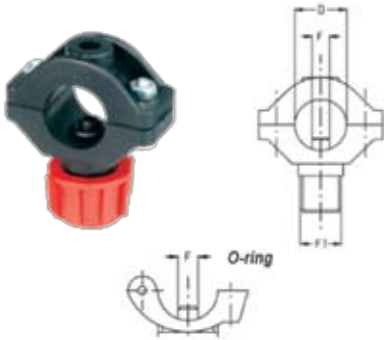

Composizione

- Cavallotto superiore
- Cavallotto inferiore
- n° 1 OR x codolo
- Ghiera filettata rossa 3/8"
- n° 2 viti M4 x 20 zincati o, a richiesta, in acciaio inox
- n° 2 dadi M4 zincati o, a richiesta, in acciaio inox

Composition

- Upper coupling sleeve
- Lower coupling sleeve
- n° 1 OR for tang
- Red taped retainer 3/8"
- n° 2 plated screws M4 X 20, on request, in stainless steel
- n° 2 plated nuts M4 X 20, on request, in stainless steel

Composición

- Horquilla superior
- Horquilla inferior
- 1 OR para espiga
- Virola roscada roja 3/8"
- 2 tornillos M4 x 20 galvanizados o, bajo pedido, en acero inox
- 2 tuercas M4 galvanizadas o, bajo pedido, en acero inox

Mod. C

D	F	Codice - Code - Codice
1/2	7 mm	PFASC3.7

RACCORDI A FASCETTA MOD. D

MOD. D SPLIT EYELET CONNECTORS
UNIONES DE ABRAZADERA MOD. D

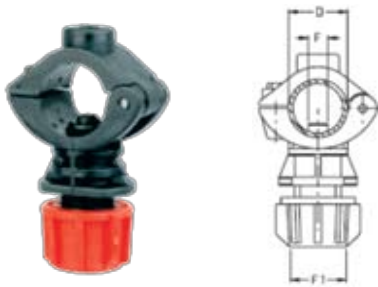

Composizione

- Portagetto con perno
- Ghiera filettata rossa 3/8"
- n° 1 vite autofilettante 3.8 x 16 inox (V00007005)
- n° 1 OR x codolo (F)

Composition

- Nozzle holder
- Red taped retainer 3/8"
- n° 1 self tapping screw 3.8 x 16 SS303 (V00007005)
- n° 1 OR for tang (F)

Composición

- Portachorros con perno
- Virola roscada roja 3/8"
- 1 tornillo auto-roscante 3.8 x 16 inox (V00007005)
- 1 OR para espiga (F)

Mod. D

D	F	Codice - Code - Código
20 mm	7 mm	PFASD20.7
20 mm	10 mm	PFASD20.1
1/2"	7 mm	PFASD3.7
1/2"	10 mm	PFASD3.10
3/4"	10 mm	PFASD4.10
1"	10 mm	PFASD5.10

RACCORDI A FASCETTA MOD. A

MOD. A SPLIT EYELET CONNECTORS
UNIONES DE ABRAZADERA MOD. A



Composizione

- Cavallotto superiore
- Cavallotto inferiore
- n° 1 OR per codolo
- n° 2 viti M4 x 20 zincati o, a richiesta, in acciaio inox
- n° 2 dadi M4 zincati o, a richiesta, in acciaio inox

Composition

- Upper coupling sleeve
- Lower coupling sleeve
- n° 1 OR for tang
- n° 2 screws M4 X 20 plating, on request, in stainless steel
- n° 2 screws M4 zinc plate, on request, in stainless steel

Composición

- Horquilla superior
- Horquilla inferior
- 1 OR para espiga
- 2 tornillos M4 x 20 galvanizados o, bajo pedido, en acero inox
- 2 tuercas M4 galvanizadas o, bajo pedido, en acero inox

Mod. A

D	F	Codice - Code - Código
20	7	* PFASA20.7

* a richiesta Ø 10 - on request Ø 10 - bajo pedido Ø 10

RACCORDI A FASCETTA MOD. B

MOD. B SPLIT EYELET CONNECTORS
UNIONES DE ABRAZADERA MOD. B

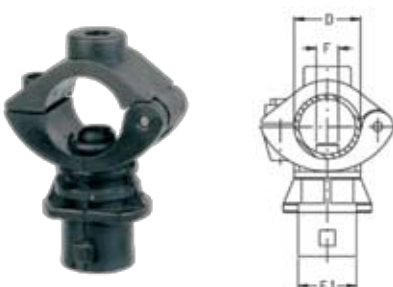

Composizione

- Portagetto a cavallotto completo
- n° 1 vite autofilettante 3.8 x 16 inox (V00007005)
- n° 1 OR x codolo (F)

Composition

- Nozzle holder with complete tang
- n° 1 self tapping screw 3.8 x 16 SS303 (V00007005)
- n° 1 OR x tang (F)

Composición

- Portachorros de horquilla completo
- 1 tornillo auto-roscante 3.8 x 16 inox (V00007005)
- 1 OR para espiga (F)

Mod. B

D	F	Codice - Code - Código
20 mm	7 mm	PFASB20.7
20 mm	10 mm	PFASB20.1
1/2"	7 mm	PFASB3.7
1/2"	10 mm	PFASB3.10
3/4"	10 mm	PFASB4.10
1"	10 mm	PFASB5.10

RACCORDI A FASCETTA MOD. E

MOD. E SPLIT EYELET CONNECTORS
UNIONES DE ABRAZADERA MOD. E

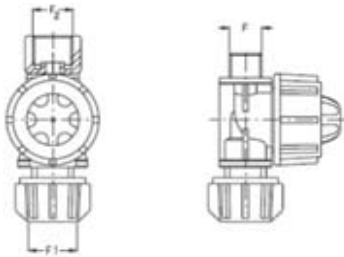

Composizione

- Portagetto filettato
- Ghiera filettata rossa 3/8"
- n° 1 ghiera a membrana
- n° 1 membrana antigoccia

Composition

- Threaded nozzle holder
- Red threaded retainer 3/8"
- n° 1 membrane retainer
- n° 1 check valve membrane

Composición

- Portachorros roscado
- Virola roscada roja 3/8"
- 1 virola de membrana
- 1 membrana antigoteo

Mod. E

D	Attacco - Thread - Rosca de conexión	Codice - Code - Código EPDM	Codice - Code - Código VITON
1/4" GAS	M	PEE 1M	PEV 1M
3/8" GAS	F	PEE 2F	PEV 2F
11/6" GAS	F	PEE 1116 F	PEV 1116 F
1/4" GAS	F	PEE 1 F	PEV 1 F

RACCORDI A FASCETTA MOD. DA

MOD. DA SPLIT EYELET CONNECTORS
UNIONES DE ABRAZADERA MOD. DA

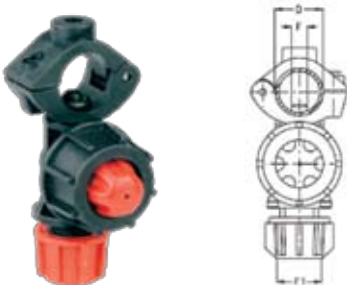

Composizione

- Portagetto con perno completo di ghiera per membrana e membrana antigoccia
- Ghiera filettata rossa 3/8"
- n° 1 ghiera per membrana
- n° 1 vite autofilettante 3.8 x 16 inox (V00007005)
- n° 1 OR x codolo (F)

Composition

- Nozzle holder with pin complete with retainer for membrane and check valve membrane
- Red taped retainer 3/8F
- n° 1 retainer for membrane
- n° 1 self tapping screw 3.8 x 16 SS303 (V00007005)
- n° 1 OR for tang (F)

Composición

- Portachorros con perno dotado de virola para membrana y membrana antigoteo
- Virola roscada roja 3/8"
- 1 virola para membrana
- 1 tornillo auto-roscante 3.8 x 16 inox (V00007005)
- 1 OR para espiga (F)

Mod. DA

D	F	Codice - Code - Código EPDM	Codice - Code - Código VITON
20 mm	7 mm	PFASDAE20.7	PFASDAV20.7
20 mm	10 mm	PFASDAE20.1	PFASDAV20.1
1/2"	7 mm	PFASDAE3.7	PFASDAV3.7
1/2"	10 mm	PFASDAE3.10	PFASDAV3.10
3/4"	10 mm	PFASDAE4.10	PFASDAV4.10
25 mm	10 mm	PFASDAE25.1	PFASDAV25.1
1"	10 mm	PFASDAE5.10	

RACCORDI A FASCETTA MOD. BA

MOD. BA SPLIT EYELET CONNECTORS
UNIONES DE ABRAZADERA MOD. BA

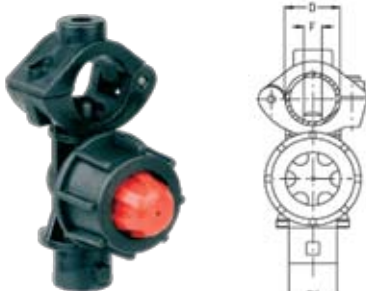

Composizione

- Portagetto a clip
- Ghiera per membrana
- n° 1 vite autofilettante 3.8 x 16 inox (V00007005)
- n° 1 OR x codolo

Composition

- Nozzle holder clip
- Retainer for membrane and check valve membrane
- n° 1 self tapping screw 3.8 x 16 SS303 (V00007005)
- n° 1 OR x tang

Composición

- Portachorros de clip
- Virola para membrana
- 1 tornillo auto-roscante 3.8 x 16 inox (V00007005)
- 1 OR para espiga

Mod. BA

D	F	Codice - Code - Código EPDM	Codice - Code - Código VITON
20 mm	7 mm	PFASBAE20.7	PFASBAV20.7
20 mm	10 mm	PFASBAE20.1	PFASBAV20.1
1/2"	7 mm	PFASBAE3.7	PFASBAV3.7
1/2"	10 mm	PFASBAE3.10	PFASBAV3.10
3/4"	10 mm	PFASBAE4.10	PFASBAV4.10
25 mm	10 mm	PFASBAE25.1	PFASBAV25.1
1"	10 mm	PFASBAE5.10	

RACCORDI FASCETTA ZINCATA
PLATED SPLIT EYELET CONNECTORS
UNIONES DE ABRAZADERA GALVANIZADA

Caratteristiche

- In acciaio zincato con corpo in ottone o acciaio inox

Characteristics

- In plated stainless steel with body in brass or SS303

Características

- En acero galvanizado con cuerpo de latón o acero inox

Come ordinare

Es. Fascetta zincata 1/2" x 1/4"

How to Order

E.g. Plated split eyelet connector 1/2" x 1/4"

Para pedidos

Ej. Abrazadera galvanizada 1/2" x 1/4"



MATERIALE MATERIAL MATERIAL	ATTACCO THREAD ROSCA DE CONEXIÓN	MODELLO MODEL MODELO	DIAMETRO DIAMETER DIÁMETRO	ANGOLO ANGLE ANGULO	CODICE ARTICLE CODE CÓDIGO
Z	-	FAS	3	-	ZFAS3

Completa di: - Complete with: - Dotada de:

Viti - Screw - Tornillos
Guarnizione - Gasket - Guarnición
Corpo - Body - Cuerpo

ZVM6*20 doppie - double - dobles
GUARNIZFAS1
OCORPO1FF

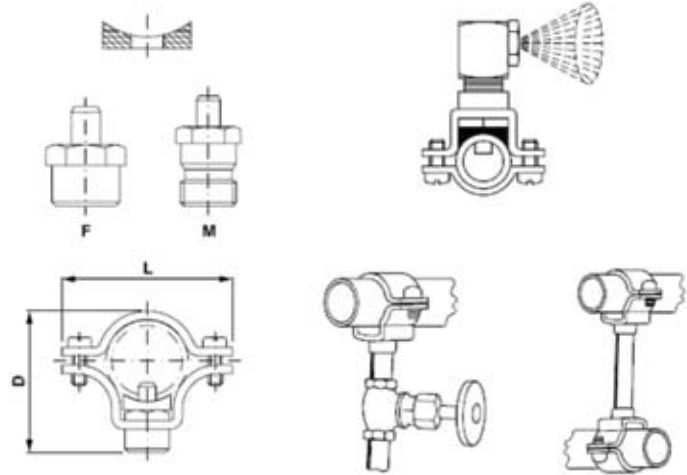

TIPO TYPE TIPOS	RACCORDO USCITA OUTLET CONNECTOR UNIÓN DE SALIDA	Ø TUBAZIONI Ø TUBES Ø TUBERÍAS	Ø FORO DI ESEG. SUL TUBO Ø HOLE Ø ORIFICIO A PRACTICAR EN EL TUBO (mm)	DIMENSIONI - DIMENSIONS - DIMENSIONES	
				L	D
1/2 x 1/8 1/2 x 1/4 1/2 x 3/8 1/25 x 11/16	1/8 F 1/4 F 3/8 F 11/16 M	Ø 1/2" Ø 20 + 22 Ø	7	50	40
3/4 x 1/8 3/4 x 1/4 3/4 x 3/8 3/4 x 11/16	1/8 F 1/4 F 3/8 F 11/16 M	3/4" Ø 25 + 27 Ø	7	50	46
1 x 1/8 1 x 1/4 1 x 3/8 1 x 1/2	1/8 F 1/4 F 3/8 F 11/16 M	1" Ø 30 + 35 Ø	7	60	46
1 1/4 x 1/8 1 1/4 x 1/4 1 1/4 x 3/8 1 1/4 x 1/2	1/8 F 1/4 F 3/8 F 1/2 F	1 1/4" Ø 40 + 45 Ø	17.5	72	61
1 1/2 x 1/8 1 1/2 x 1/4 1 1/2 x 3/8 1 1/2 x 1/2	1/8 F 1/4 F 3/8 F 1/2 F	1 1/2" Ø 45 + 51 Ø	17.5	86	67
2 x 1/8 2 x 1/4 2 x 3/8 2 x 1/2	1/8 F 1/4 F 3/8 F 1/2 F	2" Ø 54 + 60 Ø	17.5	96	75

NB: Modelli - Model - Modelos Ø 1/2 - 3/4 - 1
Pressione max - Pressure max - Presión máx: 15 bar

Modelli - Model - Modelos Ø 1 1/2 - 1 1/2 - 2
Pressione max - Pressure max - Presión máx: 10 bar

SNODO ORIENTABILE OTTONE/INOX

ADJUSTABLE SWIVELS IN BRASS/SS303
ARTICULACIÓN ORIENTABLE LATÓN/INOX



Caratteristiche

Sono costituiti da due flange stampate, 3 viti di unione e una sferainterna che assicura la perfetta tenuta per qualsiasi angolo di rotazione dell'ugello fino a 10 bar. Costruiti in ottone o acciaio inox.

Applicazioni

Sono impiegati per variare l'orientamento dello spruzzo nei vari processi di lavorazione senza modificare l'impianto.

Come ordinare

Es. Snodo 1/4"M x 1/4"F OTTONE

Characteristics

They consist of two moulded flanges, three fastening bolts and an internal ball that assures a perfect leakproof for every adjustment angle of nozzle, up to 10 bar. Made in brass or stainless steel.

Applications

They provide adjustable positioning of the spray without changing of line system.

How to Order

E.g. Swivel 1/4" M x 1/4" F BRASS

Características

Están formados por dos bridas de estampación, 3 tornillos de unión y una esfera interna que asegura la perfecta estanqueidad para todos los ángulos de rotación de las boquillas hasta los 10 bares. Construidos en latón o acero inox.

Aplicaciones

Se emplean para variar la orientación del rociado en los distintos procesos de elaboración sin modificar el sistema.

Para pedidos

Ej. Articulación 1/4"M x 1/4"H LATÓN

MATERIALE MATERIAL MATERIAL	ATTACCO THREAD ROSCA DE CONEXIÓN	MODELLO MODEL MODELO	ORIFIZIO FLOW ORIFICE ORIFICIO	ANGOLO ANGLE ANGULO	CODICE ARTICLE CODE CÓDIGO
O	-	SNODO1M1F	-	-	OSNODO1M1F

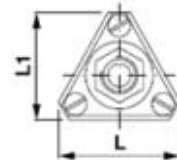
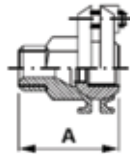
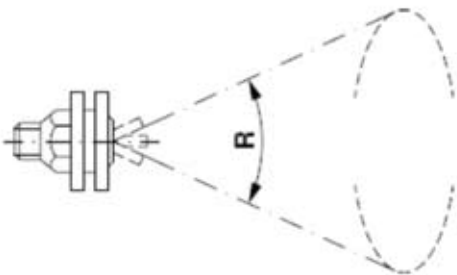

GIUNTO ORIENTABILE ADJUSTABLE SWIVEL JUNTA ORIENTABLE	RACCORDO INGRESSO INLET CONNECTOR UNIÓN DE ENTRADA	RACCORDO USCITA OUTLET CONNECTOR UNIÓN DE SALIDA	R	DIMENSIONI - DIMENSIONS - DIMENSIONES		
				A	L	L1
* 1/8 x 1/8	1/8 - M	1/8 - F	40	32	38	35
* 1/4 x 1/8	1/4 - M	1/8 - F	40	35	38	35
* 1/4 x 1/4	1/4 - M	1/4 - F	50	44	50	44
* 3/8 x 1/4	3/8 - M	1/4 - F	50	44	50	44
* 3/4 x 3/8	3/8 - M	3/8 - F	40	44	50	44
* 1/2 x 3/8	1/2 - M	3/8 - F	45	44	50	44
* 1/2 x 1/2	1/2 - M	1/2 - F	50	64	74	64
* 3/4 x 1/2	3/4 - M	1/2 - F	40	64	74	64
* 3/4 x 3/4	3/4 - M	3/4 - F	40	64	74	64
* 1 x 1/2	1 - M	1/2 - F	40	64	74	64
* 1 x 3/4	1 - M	3/4 - F	40	64	74	64

* materiali su richiesta - material on request - bajo pedido



SNODO ALTA PRESSIONE

HIGH PRESSURE SWIVELS
ARTICULACIÓN ORIENTABLE
ALTA PRESIÓN

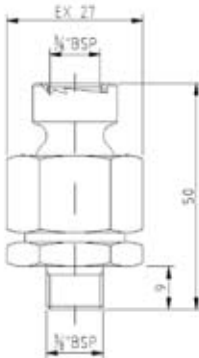

Caratteristiche

- La loro particolare conformazione permette di dirigere lo spray degli ugelli nella direzione desiderata anche in zone dove lo spazio a disposizione è esiguo
- Assicurano il corretto posizionamento del tubo di alimentazione ugelli senza dover effettuare connessioni particolari
- La totale assenza di particolari interni ed il largo passaggio consentono il corretto spray del liquido
- Le superfici a contatto particolarmente rifinite, assicurano una corretta tenuta
- Il serraggio dello snodo, risulta molto semplice e sicuro, in qualsiasi posizione della sfera
- Possono essere utilizzati ad elevate pressioni
- Le connessioni disponibili sono filettate BSP 1/8" 1/4" 3/8"
- I materiali a disposizione sono acciaio inox e a richiesta ottone

Characteristics

- Their particular shape allow turning the spray in the desired direction even where the space is very limited
- They assure a correct position of the feed tube without particular connections
- The absence of internal and the great passage allow the correct liquid jet
- The particular wheel-finished surface assure exact location.
- The closure of swivel is very easy and sure in every position of the sphere
- They may be used at high pressures
- The connections available are BSP 1/8", 1/4", 3/8" thread
- The material is stainless steel and on request brass

Características

- Su particular conformación permite dirigir la pulverización de las boquillas en la dirección deseada incluso en zonas con muy poco espacio a disposición
- Aseguran la correcta posición del tubo de alimentación de las boquillas sin necesidad de efectuar conexiones especiales
- La total ausencia de piezas internas y el ancho conducto permiten la correcta pulverización del líquido
- Las superficies en contacto, particularmente bien acabadas, aseguran una correcta estanqueidad
- El apriete de la articulación resulta muy simple y segura en todas las posiciones de la esfera
- Pueden utilizarse también a altas presiones
- Las conexiones disponibles son conexiones roscadas BSP 1/8" 1/4" 3/8"
- Los materiales a disposición son el acero inox y, bajo pedido, el latón

Come ordinare

Es. Snodo alta pressione
1/4" M x 1/4" F INOX

How to Order

E.g. High pressure swivel
1/4" M x 1/4" F STAINLESS STEEL

Para pedidos

Ej. Articulación de alta presión
1/4" M x 1/4" H INOX

MATERIALE	ATTACCO	MODELLO	ORIFIZIO	ANGOLO	CODICE
MATERIAL	THREAD	MODEL	FLOW ORIFICE	ANGLE	ARTICLE CODE
MATERIAL	ROSCA DE CONEXIÓN	MODELO	ORIFICIO	ANGULO	CÓDIGO
I	-	SNODAP1M1F	-	-	ISNODAP1M1F



PORTAUGELLO A SFERA ATTACCO RAPIDO

SPHERE NOZZLE HOLDER QUICK THREAD
PORTABOQUILLAS DE ESFERA CONEXIÓN RÁPIDA



Fascette	-	Split eyelet	-	Abrazaderas
CODICE - CODE - CÓDIGO	DESCRIZIONE - DESCRIPTION - DESCRIPCIÓN			
PFAS5AR	P-FASCETTA 1" ATTACCO RAPIDO COMPLETA DI GHIERA (SENZA CODOLO) P-SPLIT EYELET 1" QUICK CONNECTOR COMPLETE WITH RETAINER (WITHOUT TANG) P-ABRAZADERA 1" CONEXIÓN RÁPIDA CON VIROLA (SIN ESPIGA)			
PFAS6AR	P-FASCETTA 1" 1/4 ATTACCO RAPIDO COMPLETA DI GHIERA (SENZA CODOLO) P-SPLIT EYELET 1" 1/4" QUICK CONNECTOR COMPLETE WITH RETAINER (WITHOUT TANG) P-ABRAZADERA 1" 1/4 CONEXIÓN RÁPIDA CON VIROLA (SIN ESPIGA)			
PFAS7AR	P-FASCETTA 1" 1/2 ATTACCO RAPIDO COMPLETA DI GHIERA (SENZA CODOLO) P-SPLIT EYELET 1" 1/2" QUICK CONNECTOR COMPLETE WITH RETAINER (WITHOUT TANG) P-ABRAZADERA 1" 1/2 CONEXIÓN RÁPIDA CON VIROLA (SIN ESPIGA)			

Codoli	-	Tang	-	Espigas
CODICE - CODE - CÓDIGO	DESCRIZIONE - DESCRIPTION - DESCRIPCIÓN			
PFASARCOD10	CODOLO PER FASCETTA ATTACCO RAPIDO 10MM TANG FOR SPLIT EYELET QUICK CONNECTOR 10mm ESPIGA PARA ABRAZADERA DE CONEXIÓN RÁPIDA 10MM			
PFASARCOD14	CODOLO PER FASCETTA ATTACCO RAPIDO 14MM TANG FOR SPLIT EYELET QUICK CONNECTOR 14mm ESPIGA PARA ABRAZADERA DE CONEXIÓN RÁPIDA 14MM			
PFASARCOD17	CODOLO PER FASCETTA ATTACCO RAPIDO 17MM TANG FOR SPLIT EYELET QUICK CONNECTOR 17mm ESPIGA PARA ABRAZADERA DE CONEXIÓN RÁPIDA 17MM			

Sfere con OR di tenuta	-	Sphere with seal	-	Esfemas con OR de estanqueidad
CODICE - CODE - CÓDIGO	DESCRIZIONE - DESCRIPTION - DESCRIPCIÓN			
PFASARSFE0F	SFERA 1/8" F PER FASCETTA ATTACCO RAPIDO SPHERE 1/8" FOR SPLIT EYELET QUICK CONNECTOR ESFERA 1/8" H PARA ABRAZADERA DE CONEXIÓN RÁPIDA			
PFASARSFE1F	SFERA 1/4" F PER FASCETTA ATTACCO RAPIDO SPHERE 1/4" FOR SPLIT EYELET QUICK CONNECTOR ESFERA 1/4" H PARA ABRAZADERA DE CONEXIÓN RÁPIDA			
PFASARSFE2F	SFERA 3/8" F PER FASCETTA ATTACCO RAPIDO SPHERE 3/8" FOR SPLIT EYELET QUICK CONNECTOR ESFERA 3/8" H PARA ABRAZADERA DE CONEXIÓN RÁPIDA			

NB: Le fascette sono composte dai seguenti articoli
The split eyelet connector are composed by the following article
Las abrazaderas están formadas por los siguientes artículos





CODICE - CODE - CÓDIGO	DESCRIZIONE - DESCRIPTION - DESCRIPCIÓN
PFASARCAV5	CAVALLOTTO PER FASCETTA ATTACCO RAPIDO 1" U BOLT FOR SPLIT EYELET QUICK CONNECTOR 1" HORQUILLA PARA ABRAZADERA DE CONEXIÓN RÁPIDA 1"
PFASARCAV6	CAVALLOTTO PER FASCETTA ATTACCO RAPIDO 1" 1/4 U BOLT FOR SPLIT EYELET QUICK CONNECTOR 1" 1/4" HORQUILLA PARA ABRAZADERA DE CONEXIÓN RÁPIDA 1" 1/4
PFASARCAV7	CAVALLOTTO PER FASCETTA ATTACCO RAPIDO 1" 1/2 U BOLT FOR SPLIT EYELET QUICK CONNECTOR 1" 1/2" HORQUILLA PARA ABRAZADERA DE CONEXIÓN RÁPIDA 1" 1/2
PFASARPE500	PERNO PER GANCIO FASCETTA ATTACCO RAPIDO PIN FOR HOOK SPLIT EYELET QUICK CONNECTOR PERNO PARA GANCHO ABRAZADERA DE CONEXIÓN RÁPIDA
PFASARGANCI	GANCIO PER FASCETTA ATTACCO RAPIDO HOOK FOR SPLIT EYELET QUICK CONNECTOR GANCHO PARA ABRAZADERA DE CONEXIÓN RÁPIDA
PFASARPE530	PERNO PER CORPO FASCETTA ATTACCO RAPIDO (2PZ) PIN FOR BODY SPLIT EYELET QUICK CONNECTOR (2PZ) PERNO PARA CUERPO DE ABRAZADERA DE CONEXIÓN RÁPIDA (2PZ)
PFASARCORP5	CORPO PER FASCETTA ATTACCO RAPIDO 1" BODY SPLIT EYELET QUICK CONNECTOR 1" CUERPO PARA ABRAZADERA DE CONEXIÓN RÁPIDA 1"
PFASARCORP6	CORPO PER FASCETTA ATTACCO RAPIDO 1" 1/4 BODY SPLIT EYELET QUICK CONNECTOR 1" 1/4" CUERPO PARA ABRAZADERA DE CONEXIÓN RÁPIDA 1" 1/4
PFASARCORP7	CORPO PER FASCETTA ATTACCO RAPIDO 1" 1/2 BODY SPLIT EYELET QUICK CONNECTOR 1" 1/2" CUERPO PARA ABRAZADERA DE CONEXIÓN RÁPIDA 1" 1/2
PFASARGHIER	GHIERA PER FASCETTA ATTACCO RAPIDO RETAINER FOR SPLIT EYELET QUICK CONNECTOR VIROLA PARA ABRAZADERA DE CONEXIÓN RÁPIDA

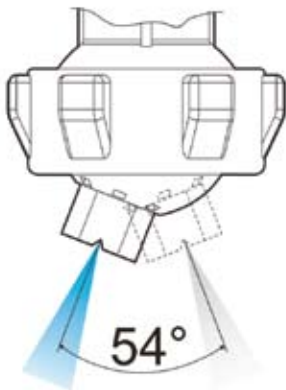
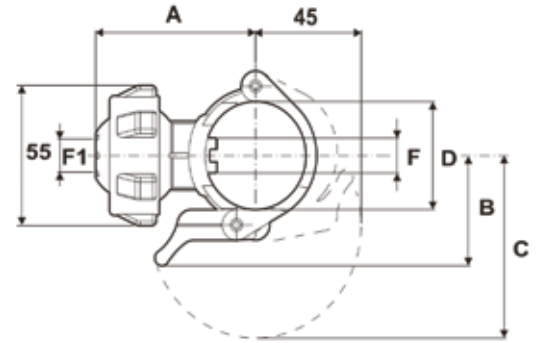

TABELLA DIMENSIONI - DIMENSION TABLE - TABLA DE MEDIDAS

F1	F	D	A	B	C
1/8" NPT 1/4" NPT 3/8" NPT	10	1"	62	39	67
1/8" NPT 1/4" NPT 3/8" NPT	14				
1/8" NPT 1/4" NPT 3/8" NPT	17				
1/8" NPT 1/4" NPT 3/8" NPT	10	1" 1/4	67	43	72
1/8" NPT 1/4" NPT 3/8" NPT	14				
1/8" NPT 1/4" NPT 3/8" NPT	17				
1/8" NPT 1/4" NPT 3/8" NPT	10	1" 1/2	71	46	75
1/8" NPT 1/4" NPT 3/8" NPT	14				
1/8" NPT 1/4" NPT 3/8" NPT	17				



CODICE - CODE - CÓDIGO	F1	F
P1MSNODO0F	 1/8"	1/4"
P1MSNODO1F	 1/4"	1/4"
P1MSNODO2F	 3/8"	1/4"
P2MSNODO0F	 1/8"	3/8"
P2MSNODO1F	 1/4"	3/8"
P2MSNODO2F	 3/8"	3/8"
P3MSNODO0F	 1/8"	1/2"
P3MSNODO1F	 1/4"	1/2"
P3MSNODO2F	 3/8"	1/2"

NB: I quadratini colorati indicano il reale colore delle sfere
 The colored squares represent the actual color of the sphere
 Los cuadraditos de color indican el verdadero color de las esferas

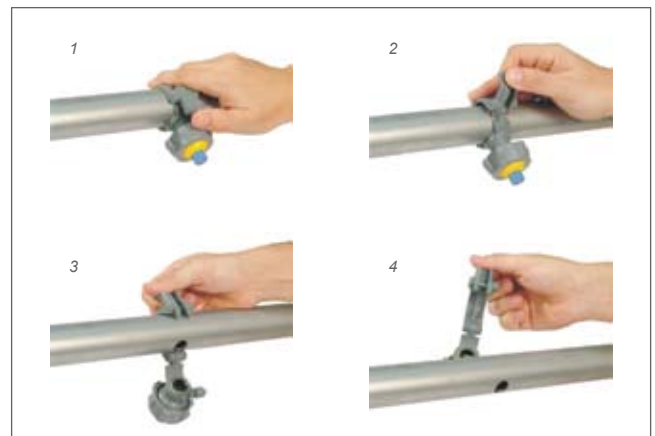
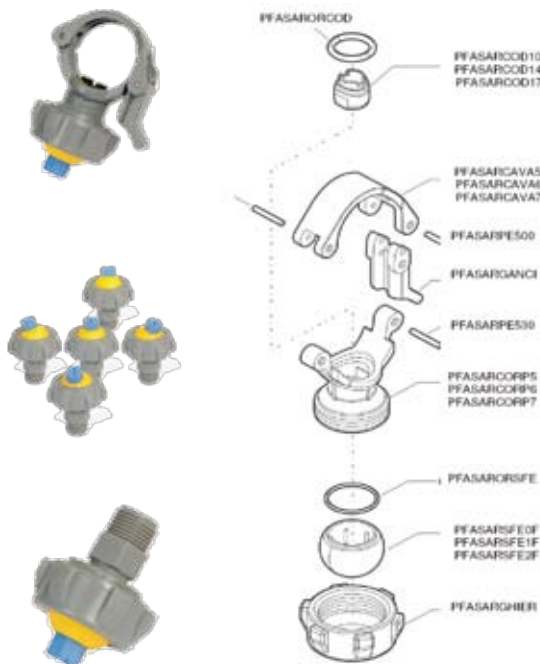

NB: Il portagetto HANDLOCK può essere montato e rimosso senza attrezzi e con una sola mano
 The nozzle holder HANDLOCK can be assembled and removed without tool and by only one hand
 El portachorros HANDLOCK puede montarse y desmontarse con una sola mano y sin herramientas

SERBATOIO PRESSURIZZATO

PRESSURE TANK
DEPÓSITO PRESURIZADO



Caratteristiche

Esistono due formati:

- **PORTATA 18 L**
altezza 565 mm
diametro 232+-2 mm
peso 4.4 kg
- **PORTATA 9 L**
altezza 341 mm
diametro 232+-2 mm
peso 3.65 kg

Materiali

- I serbatoi e le valvole sono in acciaio inossidabile ed il coperchio con maniglia è in gomma. Non ci sono parti ossidabili.

Come ordinare

Es. Serbatoio 18 LT. completo di attacchi

Characteristics

There are two types:

- **CAPACITY 18 L**
high 565 mm
diameter 232+-2 mm
weight 4,4 kg
- **CAPACITY 9 L**
High 341mm
Diameter 232+-2 mm
Weight 3,65 kg

Materials

- The pressure tank and the valves are in stainless steel and the cover with a handle in rubber. It isn't oxidable.

How to Order

E.g. Pressure tank 18 L. complete with threads

Características

Existen dos formatos:

- **CAPACIDAD 18 L**
altura 565 mm
diámetro 232+-2 mm
peso 4.4 kg
- **CAPACIDAD 9 L**
altura 341 mm
diámetro 232+-2 mm
peso 3.65 kg

Materiales

- Los depósitos y las válvulas son de acero inoxidable y la tapa con asa es de goma. No hay partes oxidables.

Para pedidos

Ej. Depósito 18 LT con Conexiones

DESCRIZIONE DEL PRODOTTO PRODUCT DESCRIPTION DESCRIPCIÓN DEL PRODUCTO	CODICE ARTICLE CODE CÓDIGO
Serbatoio 18 lt - Pressure tank 18 lt - Depósito 18 lt	SERBJ18I
Attacco rapido gas - Quick gas thread - Conexión rápida de gas	SERBJARGI
Attacco rapido prodotto - Quick product thread - Conexión rápida de producto	SERBJARPI
Kit per serbatoio - Kit for pressure tank - Kit para depósito	SERBKITATI